

NW Agility League Week 6 Double It Up 2006

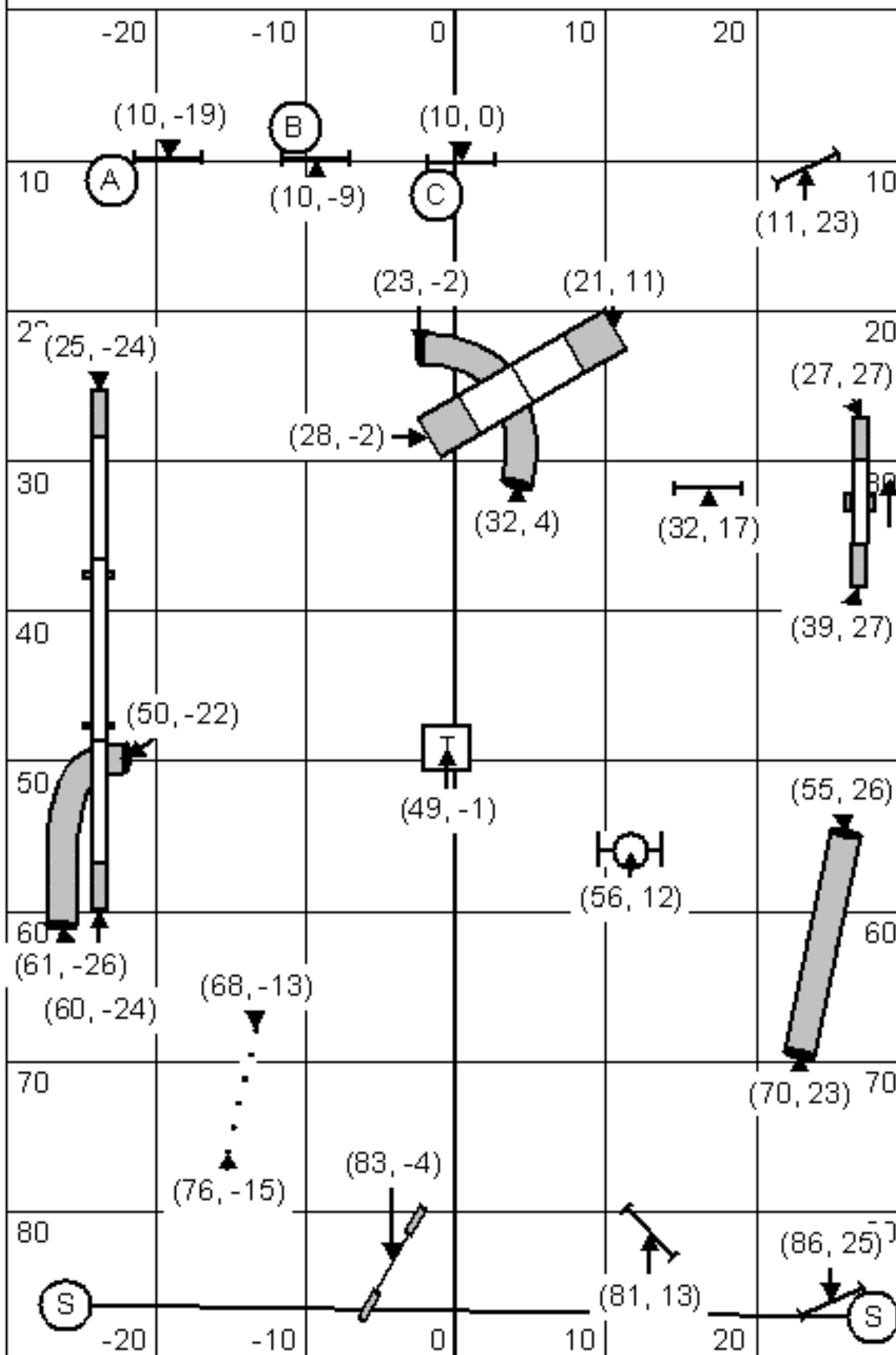

Open Dogs 50 sec., Mini Dogs 55 sec.

A-frame is doubling obstacle & table is stop obstacle.

Serpentine = 10; Contacts = 5; Tunnels, Tire, Weaves = 3; Jumps = 1.

NW Agility League Week 6 Standard Course 2006

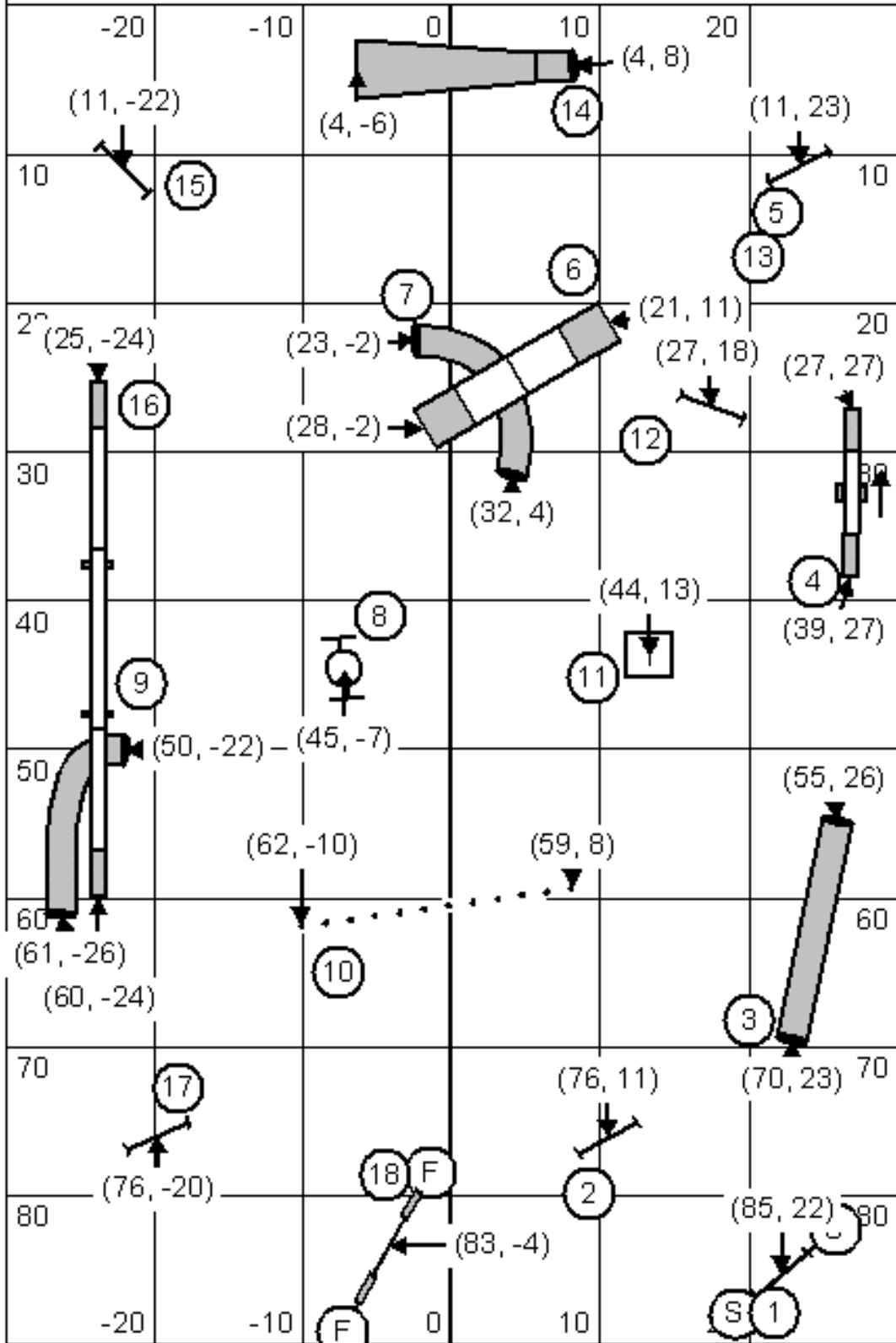

SCT Open Dogs = 63 Sec. Mini Dogs = 69 Sec.